

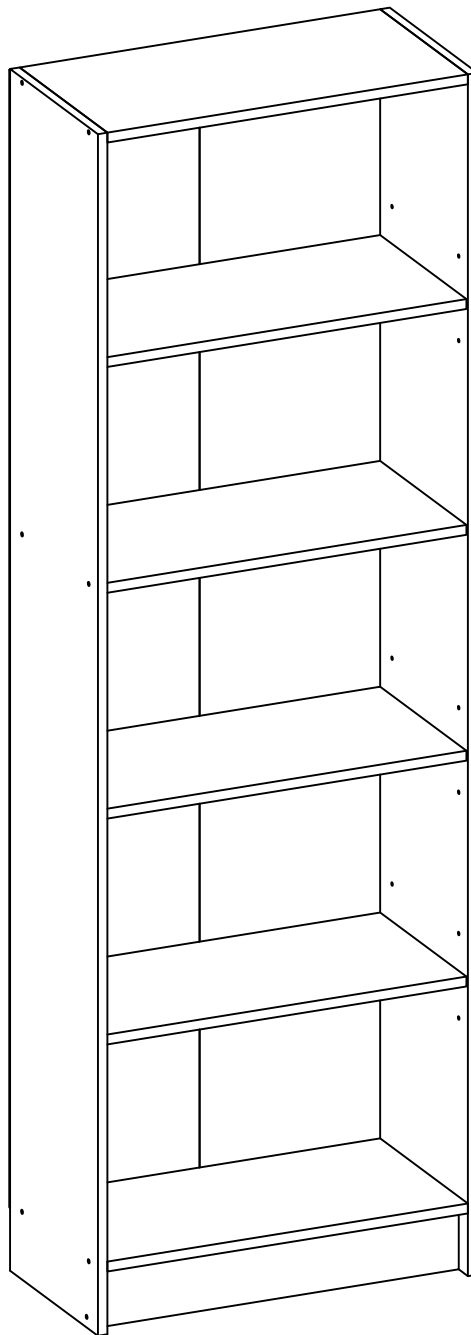

# Hodedah

[www.hodedah.com](http://www.hodedah.com)  
[support@hodedah.com](mailto:support@hodedah.com)



HID 5WD  
W23.6" x D11.6" x H71.6"





# Hodedah

[www.hodedah.com](http://www.hodedah.com)  
[support@hodedah.com](mailto:support@hodedah.com)

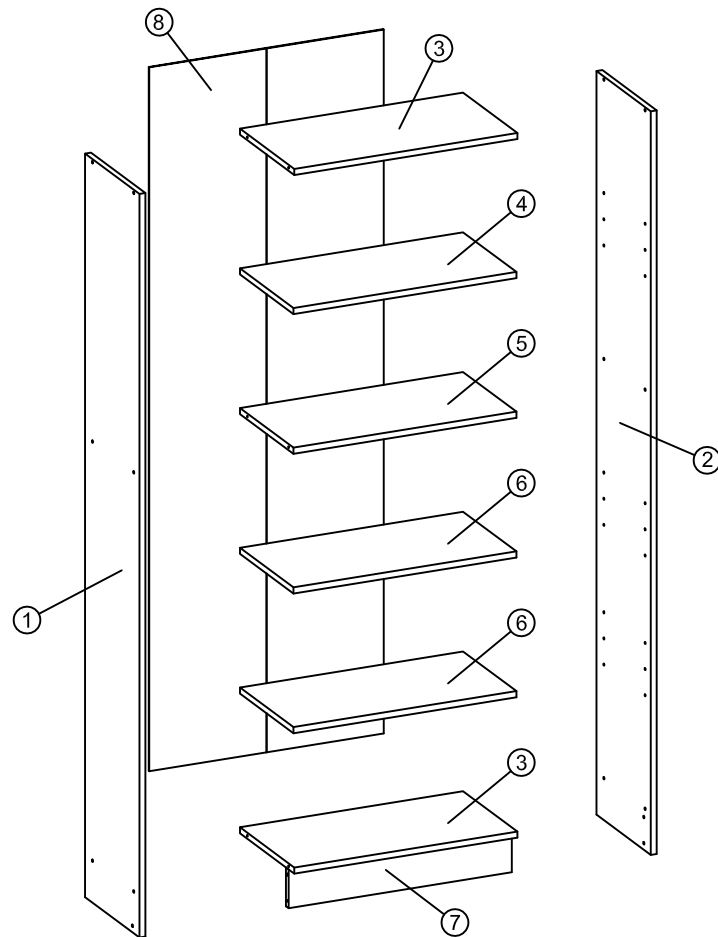
## Parts and Hardware List



A		JCBCW M5 x 40mm SCREW	14
B		M4 x 16mm CSK SCREW	4
C		WOOD DOWEL 6 x 25mm	2
D		AC51 SQUARE NAIL (15mm)	4

E		METAL SHELF SUPPORT	12
F		NAIL	30
G		ALLEN KEY	1



# Hodedah

[www.hodedah.com](http://www.hodedah.com)

[support@hodedah.com](mailto:support@hodedah.com)

- This product contains small components, please ensure that they are kept away from small children.
- THIS INSTRUCTION BOOKLET CONTAINS **IMPORTANT** SAFETY INFORMATION. PLEASE READ AND KEEP FOR FUTURE REFERENCE.



DO NOT RETURN PRODUCT TO THE STORE.

If a part is missing or damaged, email our customer service. We will gladly ship your replacement parts FREE of charge.

Need Parts or Assistance?

email us at

**[support@hodedah.com](mailto:support@hodedah.com)**

For prompt, reliable service; please have your assembly manual ready.



# Hodedah

[www.hodedah.com](http://www.hodedah.com)

[support@hodedah.com](mailto:support@hodedah.com)

Thank you for purchasing from Hodedah

**To learn more about hodedah and our products visit  
[www.hodedah.com](http://www.hodedah.com)**

## **READ BEFORE BEGINNING ASSEMBLY**

- Read each step carefully. It is very important that each step of instruction is performed in the correct order. If these steps are not followed in sequence, assembly difficulties will occur.
- Make sure all parts are included. Most parts are labeled or stamped on the raw edge.
- Work in spacious area, preferably on a carpet, near the place the unit will be used.
- Do not use power tools to assemble your furniture. Power tools may strip or damage the parts.

## **HELPFUL HINTS**

- Call us if you need assistance.
- Move your new furniture carefully, with two people lift and carry the unit to it's new location.
- Never push, drag or pull your furniture (especially on carpet).

## **Warranty Information**

Hodedah warrants this product to be free from defects in material and workmanship agrees to remedy any such defect. This warranty covers one year from the date of original purchase. This is solely limited to be repair or replacement of defective parts and no assembly labor is included.

This warranty does not apply to any product which has been improperly assembled, subjected to misuse or abuse or which has been altered or repaired in any way.

To obtain warranty service, purchaser must present original bill of sale. Components repaired or replaced warranted through the remainder of the original warranty period only. The defective components will be repaired or replaced without charge, subject to the terms and conditions described above.

**For help with assembly, identifying parts, product information or to order parts, please contact us:**

Call us at:  
718 - 456 - 0505  
Monday - Friday  
9:00 am - 5:00 pm

Visit our website:  
[www.hodedah.com](http://www.hodedah.com)



# Hodedah

[www.hodedah.com](http://www.hodedah.com)  
[support@hodedah.com](mailto:support@hodedah.com)

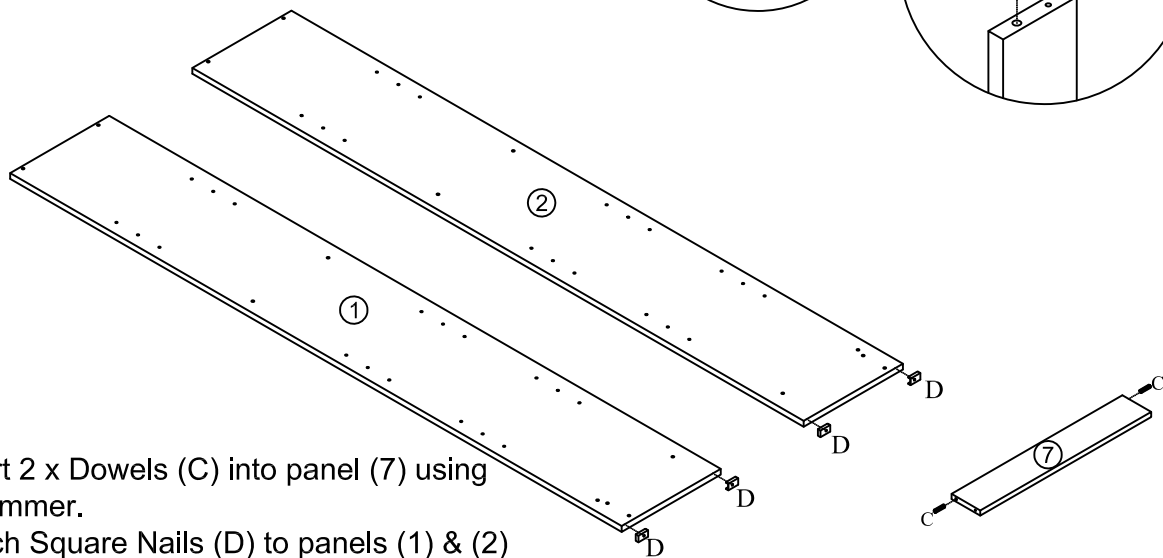
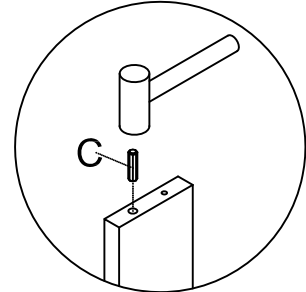
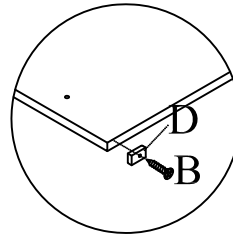

## Step 1

B		M4 x 16mm CSK SCREW	4
C		WOOD DOWEL 6 x 25mm	2
D		AC51 SQUARE NAIL (15mm)	4



- Insert 2 x Dowels (C) into panel (7) using a Hammer.
- Attach Square Nails (D) to panels (1) & (2) with 4 x CSK Screw (B) using a Phillips head screwdriver.

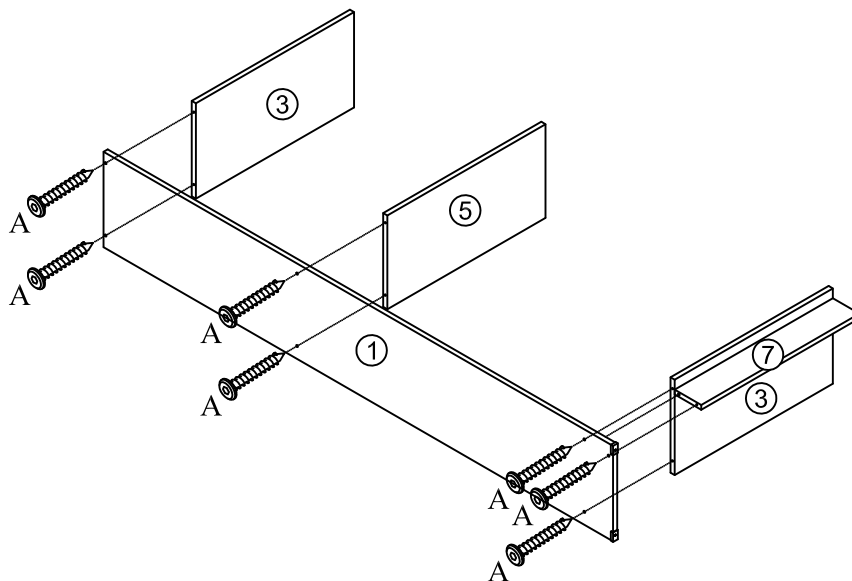

## Step 2

A		JCBCW M5 x 40mm SCREW	7
G		ALLEN KEY	1



- Attach panel (1) to panels (3) , (5) , (7).
- Insert 7 x JCBCW Screw (A) to panel (1) and tighten with a Allen Key (G).

## Step 3

A		JCBCW M5 x 40mm SCREW	7
G		ALLEN KEY	1

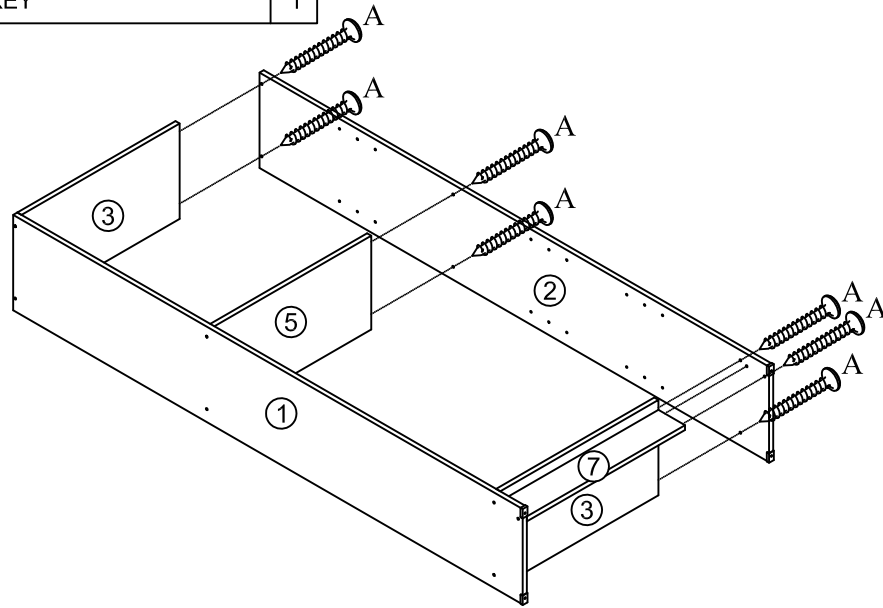

- Attach panel (2) to panels (3) , (5) , (7).
- Insert 7 x JCBCW Screw (A) to panel (2) and tighten with a Allen Key (G).

## Step 4

E		METAL SHELF SUPPORT	12
---	---	---------------------	----

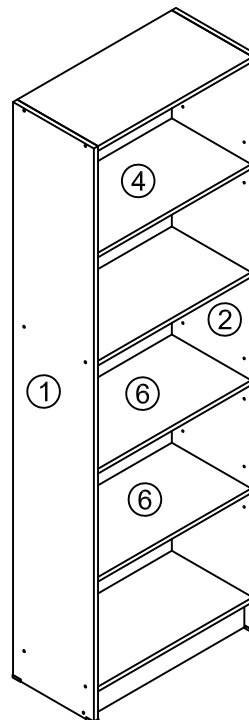
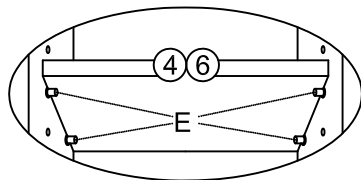

- Insert 12 x Metal Shelf Support (E) into panels (1) & (2) .
- Insert panels (4) , (6) into wardrobe .



# Hodedah

[www.hodedah.com](http://www.hodedah.com)  
[support@hodedah.com](mailto:support@hodedah.com)

## Step 5

F		NAIL	30
---	---	------	----

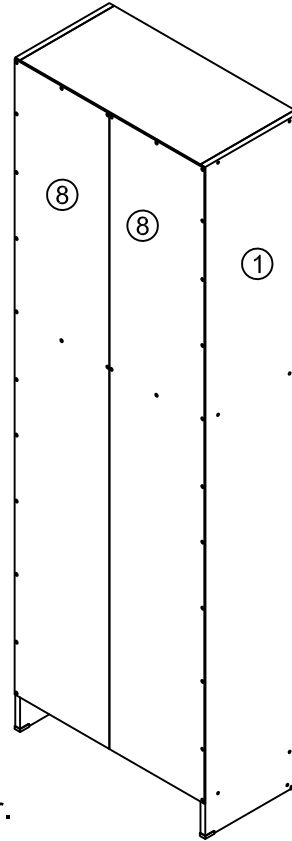
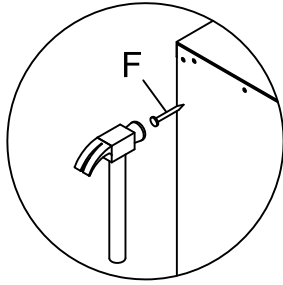

- Fix 30 x Nails (F) into panel (8) using a Hammer.

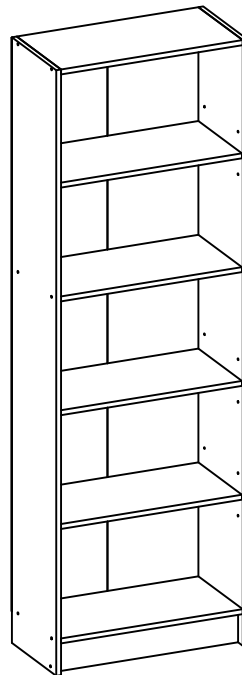

## Job Complete!

In the interest of our environment please dispose of all packaging thoughtfully.